

PADS Professional — a self-contained flow for the engineer who designs complex boards.

Overview

Until now, your choice of PCB design tools has been a frustrating compromise. High-end enterprise solutions that handle design complexity come with too much unnecessary overhead and the associated challenges of usability and cost of ownership. Desktop solutions are easier to use and have lower cost, but productivity is bogged down as design complexity increases. PADS Professional provides the tools you need for the problems you have to solve:

- You're having trouble achieving aggressive PCB design schedules
- Your current tools are running out of steam on complex designs
- Those same tools can't keep up with the newest PCB technology
- You're spending too much time cleaning up your layout before release
- Your competitors are beating you to market

The solution is PADS Professional. It brings you the best of both worlds — based on powerful Mentor Xpedition technology in combination with a focus on ease of adoption, ease of learning, ease of use, and affordability. PADS Professional directly addresses your challenges and provides the tools and horsepower to solve them.

FEATURES AND BENEFITS:

- Affordable solution for complex PCB and systems design
- Self-contained, integrated design flow in one product for hardware engineers or workgroups
- Fewer design spins with virtual prototyping including SI, PI, Thermal, DFM and 3D validation
- Easy to deploy, learn and use by both infrequent and expert users
- Constraint-driven, correct-by-construction
- Scalable as your needs grow
- Low infrastructure overhead
- Reduced design time through highly integrated capture, constraints, analysis and layout
- Reduced rework and time delays with correct-by-construction layout
- Quick, efficient design reuse
- Top-down hierarchical approach to placement and planning
- Stunning routing productivity gains with sketch routing
- Native 3D PCB design for placement, routing and MCAD collaboration

Xpedition Technology Foundation

PADS Professional is built on the same technology foundation as that used to design the world's most complex PCBs. PCB designers and hardware engineers who do it all—operating independently or in small workgroups—will find PADS Professional to be the perfect solution.

It has everything needed to design complex PCBs within a tightly integrated flow:

- Hierarchical schematic and table-based design creation with intelligent part selection and verification
- Logical and physical variant management
- Rigid-flex design capabilities
- FPGA I/O optimization to reduce signal length and layer count and eliminate costly re-spins
- Unified constraint definitions and management across the flow
- Easy design reuse of schematic, constraints and layout
- Electrical sign-off based on full-board DRC screening and signal/power integrity analysis
- Board-level thermal analysis
- Best-in-class PCB layout featuring:
 - A single layout environment
 - Concurrent 2D and 3D physical design
 - Correct-by-construction approach to placement, plane design and routing
 - Hierarchical component planning and placement
 - The industry's most powerful interactive routing environment for large busses as well as single-ended and differential pair nets
 - Ground-breaking sketch routing
 - Advanced fabrication design including HDI, RF, flex circuitry and embedded components
- Component information and library management
- Starter library with over 11,000 part numbers and IPC-7351B compliant.
- Analog/mixed signal SPICE simulation

- PCB documentation and manufacturing outputs
- Design archive management and design review

Scalability

PADS Professional can grow as the needs of your designs grow. As technology requirements and design complexities continue to expand, additional capabilities and functions can be added to the entire flow to ensure you are able to keep pace with the latest devices as well as higher speed and advances in technology.

The functionality delivered through advanced products provides capabilities previously unavailable to the individual hardware engineer who does it all and small work groups while remaining affordable and scalable.

Sharing the same Xpedition technology, PADS Professional can easily be upgraded to Xpedition Enterprise, the Mentor flagship solution for large distributed teams that need extensive library and design data management in a concurrent and collaborative design environment.

Design Without Compromise

With PADS Professional, your tools won't limit your ability to design. Unlike other systems that advertise "price conscious" tools, the PADS Professional flow is infused with vibrant, dynamic technology for a complete and comprehensive solution.

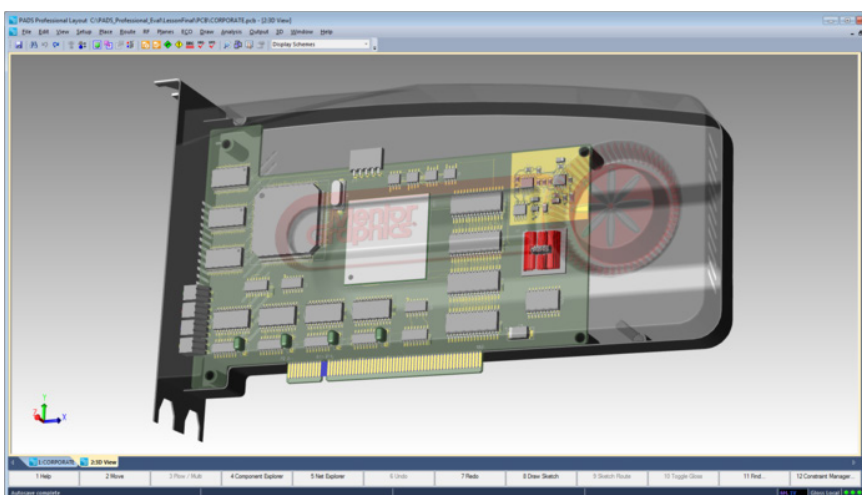

Integrated native 3D PCB design facilitates visualization, integration and collaboration with MCAD

Library and Component Information Management

PADS Professional has an integrated, correct-by-construction component library, ensuring that once a part is defined, the symbol, cell and part mappings will be in sync. This approach eliminates a major cause of design iterations commonly found in netlist-driven design solutions.

What value is the component library if you can't find the parts you need? With PADS Professional it's not a problem, because all component information is included in an easy-to-use query and verification system that accepts component information from your choice sources.

Individual engineers and small workgroups often don't have the time or resources to develop a corporate library that adheres to both company and industry standards. PADS Professional delivers an industry-proven starter library that has been developed over several years in a PCB design production environment. This library includes schematic symbols and PCB footprints that will enable you to start designing immediately. There's no need for you to spend valuable time searching for manufacturing datasheets and building your own library from scratch.

The starter library contains over 11,000 current manufacturer's part numbers and includes a wide variety of device types, well-defined partitions for easy navigation, and descriptions of the standards which were used to create the library, which is also IPC-7351B compliant.

Design Archive Management

Engineers like to try a multitude of "what-ifs" during the design cycle. The problem is keeping track of it all — file naming conventions just don't cut it.

PADS Professional includes an intuitive design archive manager that allows engineers to create and restore design archives, view and compare different archives, and create custom reports.

Design Definition

PADS Professional allows schematic or table-driven design entry of digital, analog/mixed signal, and RF circuits. Unlimited hierarchy lets you organize your design and makes for easy design reuse. If you are using hierarchy, you will need the powerful search and edit capabilities that are hierarchy-aware.

Variant management allows you to reuse a single schematic for different variants of your design, and this capability extends into layout as well.

Project and design navigation is intuitive, while the built-in component information browser allows you to easily research and instantiate parts on your schematic.

Extensive rule checking eliminates errors prior to layout, increasing the quality of your design. Tight integration, including cross probing, keeps your schematic, constraints and layout in sync at all times, allowing you to manage and track changes as your design progresses.

FPGA I/O Optimization

Today's FPGAs are very powerful devices with high pin count, numerous I/O standards and high-speed capabilities. In addition, advanced implemented logic in the FPGA very often requires that hundreds of logical signals be mapped to physical signals. This is a challenge for hardware engineers to match the HDL world with the electrical world.

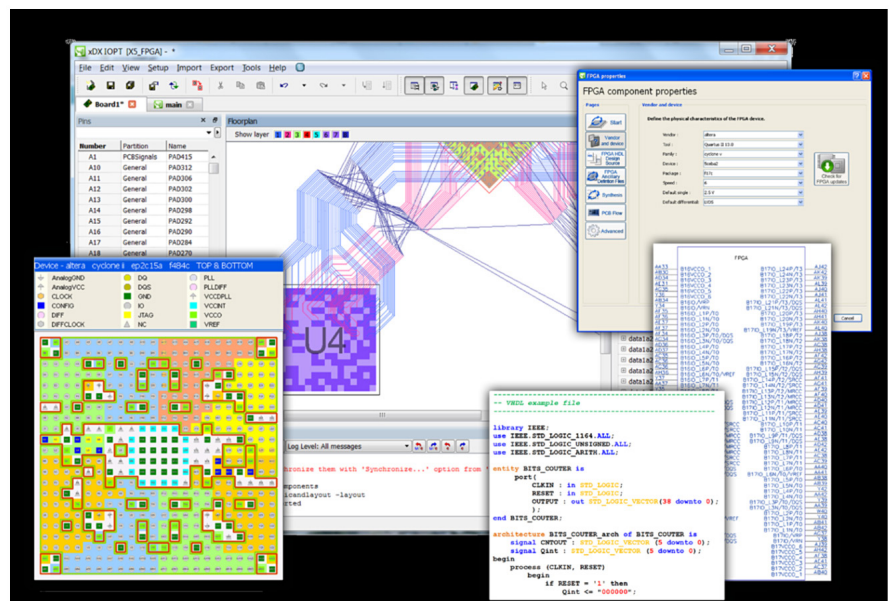

PADS Professional bridges HDL-based FPGA design and PCB design for automated, fast and error-free, bi-directional information exchange.

An automated FPGA symbol generation process typically saves as much as 30X over traditional manual processes. The process uses correct-by-construction, rule-driven I/O assignment with a library of FPGA vendor devices, including early access to not-yet-released devices.

In light of these challenges, PADS Professional fully supports FPGA-on-board integration, reducing time-to-market and manufacturing costs through reduced layer counts, via counts and design cycle time.

Achieving Electrical Sign-off

PADS Professional includes a powerful and fast design rule checking tool that verifies complex design rules that are not easily simulated, such as rules for EMI/EMC. With support for design rule checks for items such as traces crossing splits, reference plane changes, shielding, and via checks, you can quickly and easily pinpoint trouble spots on your board that can cause issues with EMI/ EMC, signal integrity, and power integrity.

The combination of design rule checking for full-board screening with advanced signal/power integrity analysis provides you with a fast, accurate solution for achieving electrical sign-off.

Constraint Management

As PCBs increase in complexity and density, a higher percentage of the design must be implemented with strict adherence to design rules. Manual documentation, translation, and interpretation of design rules often cause longer product development cycles and increased costs. The constraint manager provides a fully integrated, constraint-driven design methodology that reduces design costs and time-to-market by automating design rule communication and eliminating unnecessary PCB prototypes and re-spins. The constraint manager provides the engineer with direct control over the PCB layout.

The constraint manager supports bi-directional cross probing, highlighting and selecting between a spreadsheet-based constraint interface, schematic capture and PCB layout. Any net can be analyzed for signal integrity pre-layout when developing a topology template, which can then be used in the constraint manager.

As the number and complexity of constraints explodes, the constraint manager comes with a lightweight, easy-to-learn, context-sensitive tool for editing constraints within the schematic or PCB layout.

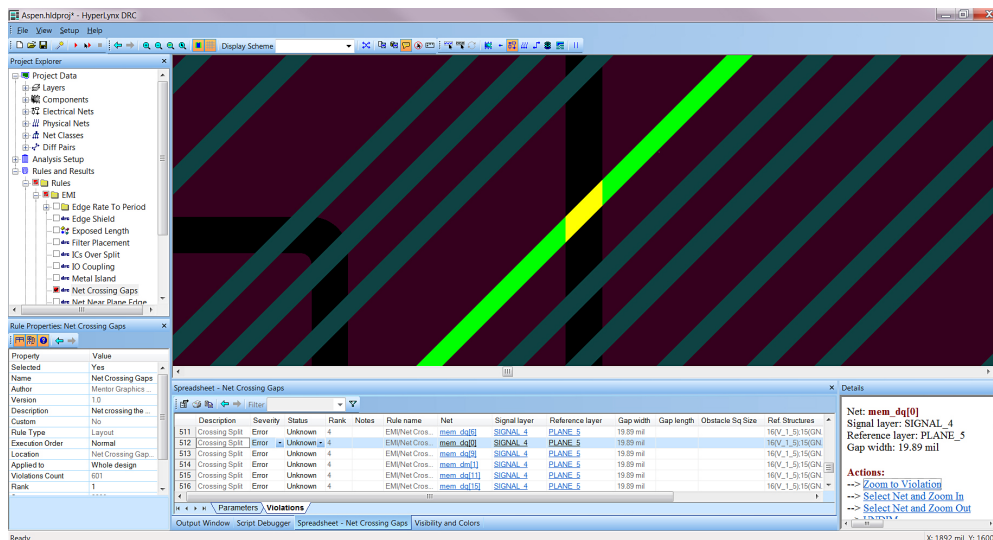

Design rule checks can be performed on boards for EMI/EMC issues, as well as signal integrity and power integrity issues. It is highly customizable, allowing users to create DRCs for any check they might otherwise perform manually.

Analog/Mixed-Signal Simulation

PADS Professional includes advanced circuit simulation with comprehensive analysis for analog, mixed-signal, and mixed-technology PCB circuits. Bring circuits in from PADS AMS Cloud to drive simulation, then use powerful SPICE and VHDL-based technologies to help understand and verify circuit behavior.

With PADS Professional you can also optimize for real-world variability by exploring various scenarios to determine which parameters or conditions most affect circuit performance.

Thermal Analysis

PADS Professional incorporates thermal analysis to allow engineers to analyze board-level thermal problems on placed, partially routed, or fully routed PCB designs. Temperature profiles, gradients, and excess temperature maps enable engineers to resolve board and component overheating early in the design process.

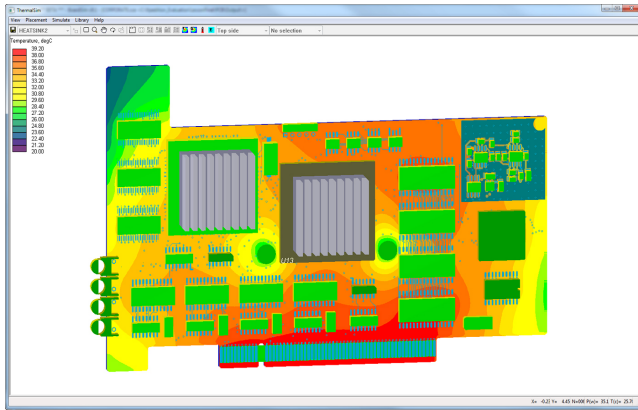

Integrated thermal analysis allows engineers to detect potential heat problems without expensive prototyping.

Signal Integrity Analysis

PADS Professional offers powerful and easy-to-use signal integrity capabilities, including DDRx validation. With pre-layout analysis capabilities for defining stackup and routing constraints and verification of the routed board to ensure your design goals are met, PADS Professional offers a rich environment for your signal integrity analysis needs based on renowned HyperLynx technology.

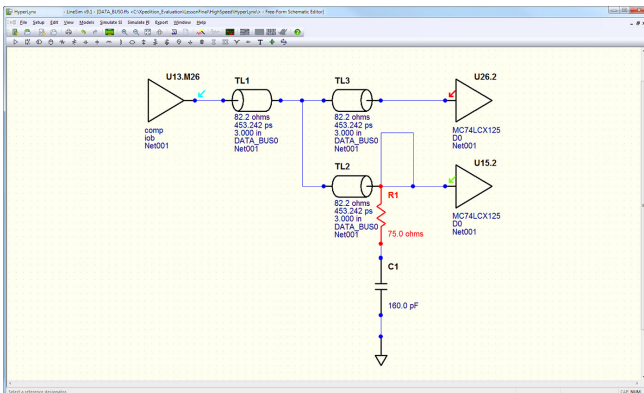

The analysis environment is tightly integrated with schematic and layout, simplifying signal integrity analysis.

Power Integrity Analysis

The power integrity analysis environment is easy to set up and use, getting simulation results without requiring weeks of software training. You can identify power distribution problems early in the design, even prior to layout. You can also identify IR drop problems with your design that would be difficult to identify in the lab, and investigate solutions in an easy-to-use “what-if” environment. Once the layout is complete, you can validate the results to ensure that appropriate guidelines were followed. This will ultimately help you reduce prototype spins and get to market faster, while creating more reliable products.

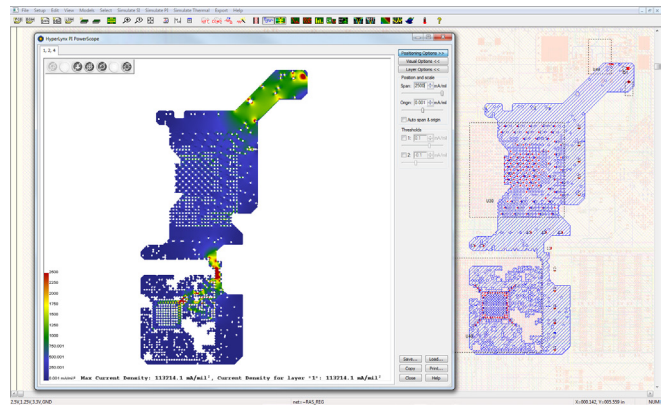

Tight integration makes power integrity analysis easier to use.

PCB Layout

At the heart of PADS Professional is the industry's most powerful PCB layout technology, all within a single editing environment. Xpedition technology is used to design the world's most complex boards that include complex, constrained topologies and power distribution, differential pairs, wide busses, HDI, flex and large, fine-pitch BGAs.

PADS Professional supports a correct-by-construction approach that produces high-quality results and reduces costly iterative clean-up of constraint violations. Dynamic glossing of traces reduces segments, prevents acute angles and obeys pad entry rules. Dynamic high performance healing of planes and thermal reliefs allows real-time creation of complex power distribution topologies. Fully integrated true parametric 3D layout with placement, constraints, DRC checking, and photorealistic visualization minimizes MCAD iterations.

PADS Professional includes revolutionary placement and interactive routing technology focused on productivity. Hierarchical group placement allows you to take advantage of natural or defined component groupings in

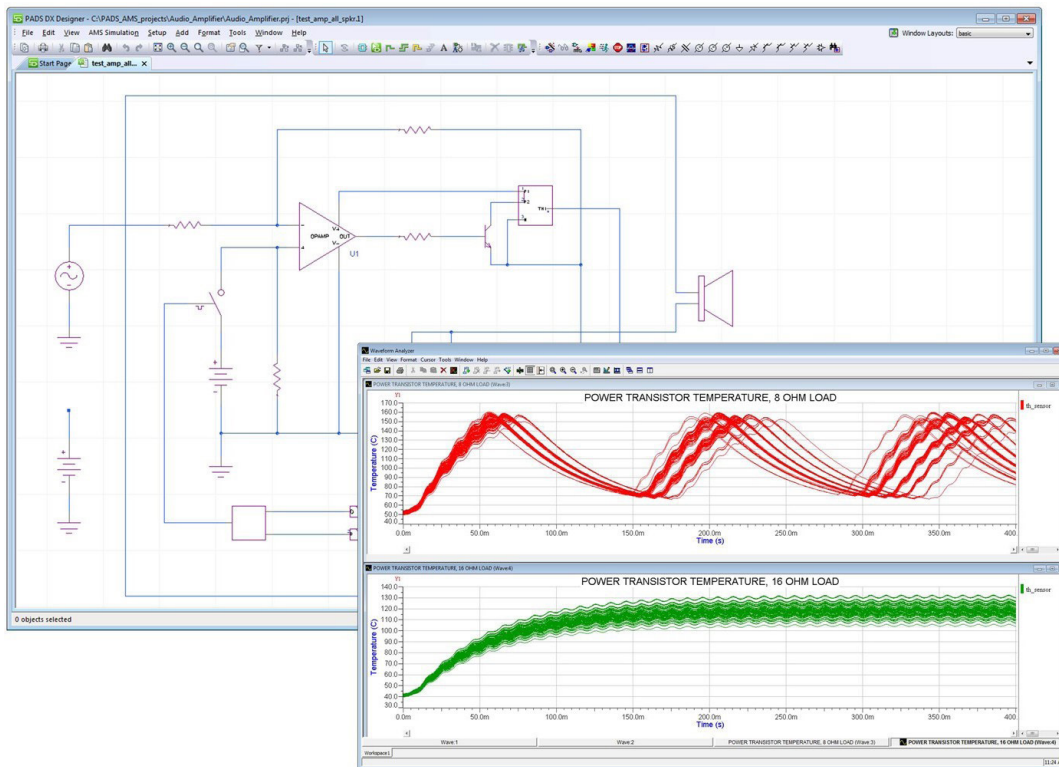

Powerful data measurements, waveform viewers, and post-processing calculators speed review and analysis of analog, mixed-signal, and mixed-technology circuits

your design when placing your board. PADS Professional combines automatic and interactive technology, keeping you in control while automating the more mundane tasks. You'll be amazed at the sheer power of the glossing, push and shove during trace manipulation.

Sketch Router

In addition, the ground-breaking sketch routing in PADS Professional takes productivity to a whole new level. Taking your design intent and routing strategies in the form of a super-efficient sketch, the system automatically fans out, untangles, and routes the associated nets with the quality of an experienced PCB designer. Sketch routing reduces complex routing times by orders of magnitude.

Starting with the Sketch Router, a designer can draw a sketch path to dictate the location for the routing of the selected netlines. The Sketch Router will route individual, dozens, or even hundreds of netlines many times faster than manual routing. Sketch routing focuses on quality; little cleanup is needed, often none at all. The high routing completion rate (typically >90%) is due to its ability to automatically optimize the escapes from components like BGAs so they are optimal for routing without any additional vias.

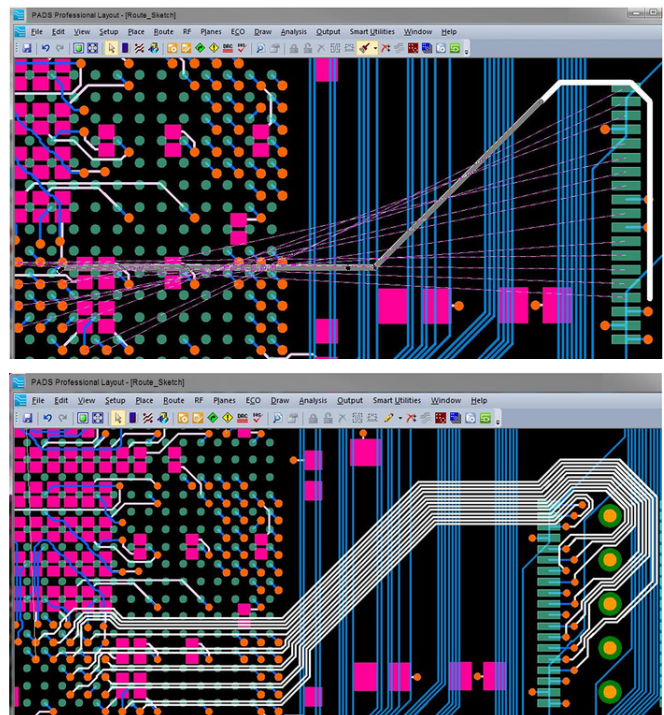

New routing technology allows the designer to sketch the path of signals, then the interactive router efficiently routes those traces. In the top image, the designer has "sketched" the path desired for the signals shown in purple. In the bottom illustration, the Sketch Router has efficiently routed the traces according to the designer's sketch.

3D Layout

One of the challenges to integrating your PCB design process into the electromechanical world is the ability to “left-shift” validation into the PCB layout processes to find electromechanical design problems early, eliminating costly re-design late in the cycle. 3D layout is a fully integrated 2D/3D environment using the same selection, planning and placement functionality as PCB layout.

The true parametric 3D mechanical kernel uses a complete set of 3D constraints with dynamic collision detection and batch verification to ensure your electromechanical designs are error-free. Full photo-realistic visualization of board elements, like traces, components, silk screen, solder mask, and vias, is provided with transparency, z-axis scaling, view/rotation control, and x/y/z cut planes.

Import mechanical like chassis and heat sinks, and even sub-assemblies of other PCB designs, providing true mechanical multi-board capability.

Once your design is complete, you can use the integrated MCAD Collaboration tool to pass information to popular industry mechanical design systems. You can also export your design in standard industry formats and utilize the 3D PDF and documentation tools to complete your design package.

Rigid-Flex Design

The correct-by-construction environment in the PADS Professional Rigid-Flex option simplifies the design process from creation of complex rigid-flex stack-ups, to definition of bend areas with associated constraints, to accurate output for manufacturing. Intelligent recognition of flex design elements lets you make changes at any point to optimize the rigid-flex system, helping you achieve smaller, cheaper, more reliable products.

Define stack-up regions by multiple board outlines to simplify modifications. Define unique stack-up types (e.g. embedded or bikini cover lay, stiffeners). Bend areas define where and how the design will bend. Flex-aware placement and routing produces high-quality results.

RF Design

PADS Professional offers an optional solution for integrated, multi-technology RF design. Developed in collaboration with expert RF designers and RF simulation vendors, the Advanced RF Design option adds integration of packaged parts, RF component design, parametric circuit design, design optimization, and integration with interaction analysis, design validation, and design trouble-shooting to guide you quickly and safely from start to finish.

PCB Manufacturing

Manufacturing documentation and outputs can be directly created within the layout environment, so any last-minute layout changes are automatically synchronized.

Automated and customizable creation and distribution of manufacturing data results in increased quality, accuracy and design throughput. PADS Professional is also tightly integrated with Valor NPI for concurrent DFM validation and optimized hand-off to manufacturing using the ODB++ format to ensure that all manufacturing data is included and synchronized and that design intent is maintained. Additional CAM formats and reporting, including Gerber, NC drill, and pick and place, are also supported.

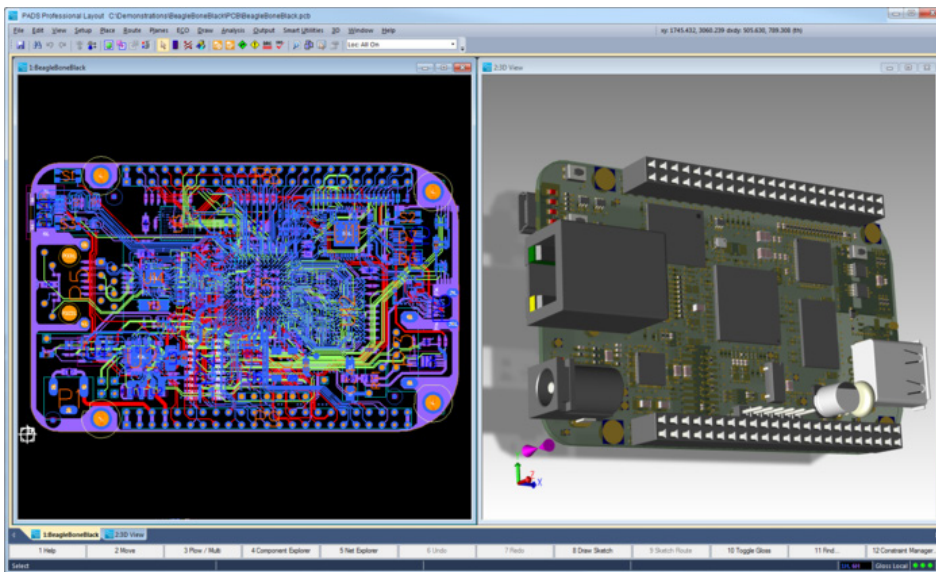

3D visualization, placement and validation optimizes PCB electromechanical design.

Multi-Trace HSD

High-speed memory interfaces and other sensitive connections multiply design complexity. Designers need more advanced tools to meet tighter and tighter constraints. The PADS Professional Multi-Trace HSD Tuning option offers high-speed design features and automation to reduce design time by quickly defining, tuning, and reviewing complex nets. Multiple methods for tuning traces in your design are provided to quickly match lengths of high-speed routes.

No Compromise

PADS Professional directly addresses your technological challenges and provides the tools and horsepower to solve them. Achieve those aggressive design schedules and stay ahead of the competition, confident in the knowledge that you have the right tools to address those complex challenges not just today, but tomorrow as well.

PADS Professional is the best of both worlds — powerful Mentor Xpedition technology combined with a focus on ease of adoption, ease of learning, ease of use, and affordability.

For the latest product information, call us or visit: www.pads.com

©2019 Mentor, A Siemens Business, all rights reserved. This document contains information that is proprietary to Mentor Graphics Corporation and may be duplicated in whole or in part by the original recipient for internal business purposes only, provided that this entire notice appears in all copies. In accepting this document, the recipient agrees to make every reasonable effort to prevent unauthorized use of this information. All trademarks mentioned in this document are the trademarks of their respective owners.

Corporate Headquarters
Mentor Graphics Corporation
8005 SW Boeckman Road
Wilsonville, OR 97070-7777
Phone: 503.685.7000
Fax: 503.685.1204

Sales and Product Information
Phone: 800.547.3000
sales_info@mentor.com

Silicon Valley
Mentor Graphics Corporation
46871 Bayside Parkway
Fremont, CA 94538 USA
Phone: 510.354.7400
Fax: 510.354.7467

North American Support Center
Phone: 800.547.4303

Europe
Mentor Graphics
Deutschland GmbH
Arnulfstrasse 201
80634 Munich
Germany
Phone: +49.89.57096.0
Fax: +49.89.57096.400

Pacific Rim
Mentor Graphics (Taiwan)
11F, No. 120, Section 2,
Gongdao 5th Road
HsinChu City 300,
Taiwan, ROC
Phone: 886.3.513.1000
Fax: 886.3.573.4734

Japan
Mentor Graphics Japan Co., Ltd.
Gotenyama Trust Tower
7-35, Kita-Shinagawa 4-chome
Shinagawa-Ku, Tokyo 140-0001
Japan
Phone: +81.3.5488.3033
Fax: +81.3.5488.3004

Mentor[®]
A Siemens Business

MGC 12-19 1031050-W